



Sprint 230V/BR 36V

HYDRAULIC BARRIER FOR BEAMS UPTO 5 M
BARRIERA IDRAULICA PER PASSAGGI FINO A 5 M

Gold
3 Years
Warranty



- **Adjustable mechanical limit switches.**
Optional electronic limit switches
Finecorsa meccanici regolabili. Microswitch elettronici (opzionali per funzione rallentamento)
- **Cataphoresis treated and polyester painted steel casing for long time lasting, INOX (316) steel casing available**
Cofano in acciaio con trattamento in cataforesi e verniciatura in poliestere per la massima resistenza nel tempo. Disponibile cofano in acciaio INOX (316).
- **Possibility to add emergency batteries to guarantee the operation also in case of power failure**
Possibilità di aggiungere batterie di emergenza per garantire il funzionamento anche in caso di mancanza di alimentazione
- **SPRINT BR 36V equipped with Absolute Encoder**
Encoder Assoluto su modello SPRINT BR 36V

new



By pass valves and manual release

Valvole by pass e sblocco manuale

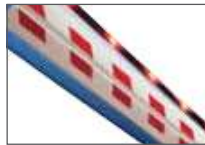

Strip LED - IP67 - LED light

Strip a LED - IP67



Control unit UNIGATE

Centrale elettronica UNIGATE



On request quick release

Sgancio rapido su richiesta

CODE CODICE	NAME PRODOTTO	UNIGATE INVERTER	OPENING TIME TEMPO APERTURA	MAX BEAM LENGTH LUNGHEZZA MAX ASTA (m)	PUMP/POMPA (l)	MAX DUTY CYCLES/ MAX CICLI USO (%)	PCS PALLET PEZZI PALLET	PRICE/PREZZO (€)	QX (PCS)	QX1 (PCS)
11703000IV	SPRINT 230V IV with UNIGATE Inverter	IVI	4 - 7 sec.	6,0	n.d.	100 %	8	2.046,00	10	20
11703000-A	SPRINT 230V 1 liter with GATE 1 DG	-	8 - 10 sec.	6,0	1,0	75 %	8	1.732,00	10	20
11703105	SPRINT BR 36V (Brushless)with Absolute new	-	2 - 6 sec.	6,0		100 %	8	2.118,00		

Foundation plate included. / Piastra di fondazione inclusa.
On request stainless steel casing / Su richiesta cofano in acciaio INOX



BR =Brushless

Operator with the electronic board UNIGATE BR
Operatore dotato di scheda elettronica UNIGATE BR



IVI =inverter

The motor is equipped with the electronic board UNIGATE INVERTER
Il motore è dotato di scheda elettronica UNIGATE INVERTER

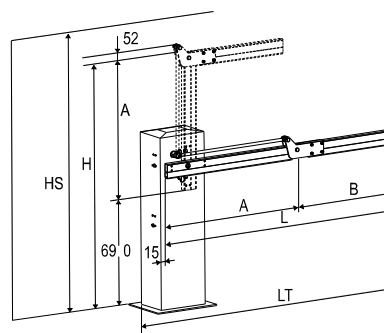
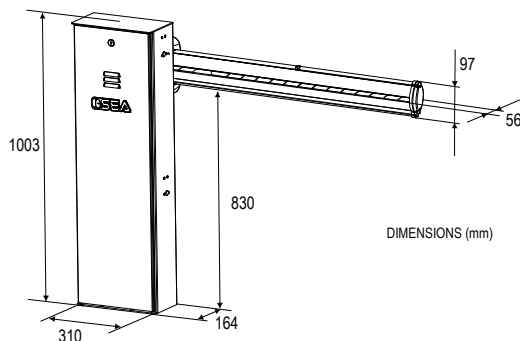



11903100

KIT LIGHTTH 3SP FIX
3 m oval beam + balancing spring + blunt-free rubber + beam profile for STRIP LED (sticker not included)
Asta ovale 3 m + molla + gomma antiscivolo + profilo asta per STRIP LED (nastro adesivo non incluso)

11903106

KIT LIGHTTH 4SP FIX +MB
3m+1m oval beam + balancing spring + blunt-free rubber + beam profile for STRIP LED (sticker not included)
Asta ovale 3 m+1m + molla + gomma antiscivolo + profilo asta per STRIP LED (nastro adesivo non incluso)

11903111

KIT LIGHTTH 5SP FIX + MB
3m+2m oval beam + balancing spring + blunt-free rubber + beam profile for STRIP LED (sticker not included)
Asta ovale 3 m + 2 m + molla + gomma antiscivolo + profilo asta per STRIP LED (nastro adesivo non incluso)

11903113

KIT LIGHTTH 6SP FIX + MB
3m+3m oval beam + balancing spring + blunt-free rubber + beam profile for STRIP LED (sticker not included)
Asta ovale 3 m + 3 m + molla + gomma antiscivolo + profilo asta per STRIP LED (nastro adesivo non incluso)

ACCESSORIES • ACCESSORI



12710091

SK3 * KIT 3 m Skirt + spring
Kit siepe 3 m + molla

12710092

SK3,5 * KIT 3,5 m Skirt + spring
Kit siepe 3,5 m + molla

12710093

SK4 * KIT 4 m skirt + spring for LINEAR
Kit siepe 4 m + molla

12710087

SUPL Pliable support for oval LIGHT beam
Supporto pieghevole per asta ovale

12715220 (*)

STICKER Red Sticker for beam (pack of 50 m)
Nastro adesivo bianco/rosso per asta (confezione 50 m)

12710120

KIT ART Kit for articulated oval beam up to max 4 m
Kit Kit per asta articolata fino a 4m

23105441

STRIP LED5 - IP67 for beam up to 5 m
Strip LED IP 67 + (per aste fino a 5 m)

23105446

STRIP LED8 - IP67 for beam up to 8 m
Strip LED IP 67 (per aste fino a 8 m)



12710797

3 m round beam Kit with RAPID RELEASE (with spring and bracket ø 70 mm)
Kit asta tonda 3 m con SGANCIO RAPIDO (con molla e staffa ø 70 mm)

12710798

4 m round beam Kit with RAPID RELEASE (with spring and bracket ø 70 mm)
Kit asta tonda 4 m con SGANCIO RAPIDO (con molla e staffa ø 70 mm)

10920805-1

SUPLIGHTP Fork support
Supporto a forcella

16200045

CSUPLIGHT Counter plate for fork support
Contropiastra per supporto forcella

23101102

ESUN Q BR Battery charger 800 mA with solar panel admin
Caricabatterie 800 mA con gestione pannello solare

23106305

BAT7 (7AH) Battery kit with box
Batterie con scatola (7AH)

23106371

Kit SUNNY BR 20W solar panel + control unit ESUN Q + battery 12 Ah
Pannello solare 20W + ESUN Q + batterie 12 Ah

12701435

POSITION GATE RT Absolute encoder
Encoder assoluto

*** The STRIP LED can be used only for the first part of the beam just up to the articulation / Lo STRIP LED può essere utilizzato solo per la prima parte del fascio solo fino all'articolazione
Note: For 4/5m beams it is recommended to install 10920805-1 or 12710087 / NB: Per aste di lunghezza 4-5 m è sempre consigliabile l'installazione di 10920805-1 oppure 12710087.
Note: LIGHT-ART on request cut up to 3m following the drawing / ***LIGHT-ART Su richiesta taglio fino a max 3,5 m secondo disegno
Note: Respect the opening times in relation to the length of the beam (see instruction manual) / Nota: Rispettare i tempi di apertura in relazione alla lunghezza della trave (vedi manuale di istruzioni) /